

LI0402C470R-10

UNCONTROLLED DOCUMENT

PHYSICAL DIMENSIONS:

| | | | |
|---|-------------|--------|-------------|
| A | 1.00 [.040] | + - | 0.15 [.006] |
| B | 0.50 [.020] | + - | 0.15 [.006] |
| C | 0.50 [.020] | + - | 0.15 [.006] |
| D | 0.30 [.012] | + - | MAX. |

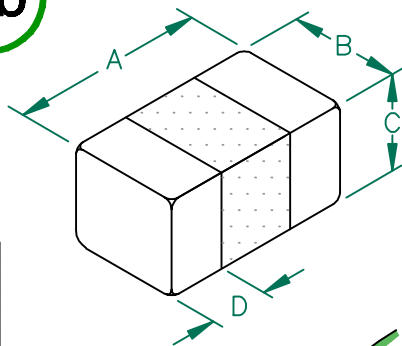

ELECTRICAL CHARACTERISTICS:

| | Z @ 100MHz (Ω) | DCR (Ω) | Rated Current |
|---------|----------------------------|---------------------|---------------|
| Nominal | 47 | | |
| Minimum | 35 | | |
| Maximum | 59 | 0.15 | 300 mA |

NOTES: UNLESS OTHERWISE SPECIFIED

- TAPED AND REELED per CURRENT EIA SPECIFICATIONS
7" REELS, 10,000 PCS/REEL, PAPER TAPE.
- TERMINATION FINISH IS 100% TIN.
- COMPONENTS SHOULD BE ADEQUATELY PREHEATED BEFORE SOLDERING.

Z vs FREQUENCY
IMPEDANCE UNDER DC BIAS

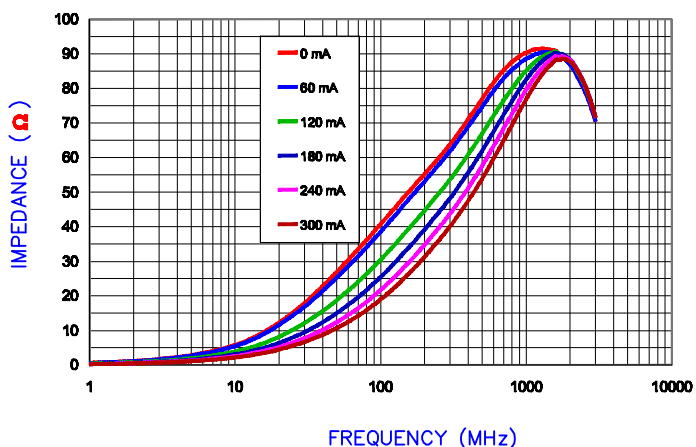

LAND PATTERNS FOR REFLOW SOLDERING

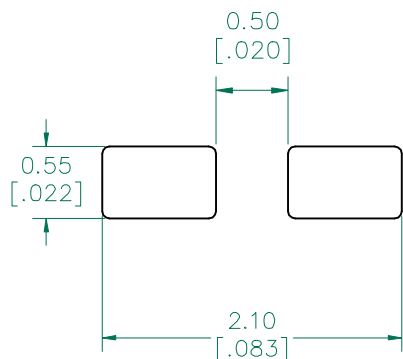

(For wave soldering, add 0.762 [.030] to this dimension.)

RECOMMENDED SOLDERING CONDITIONS

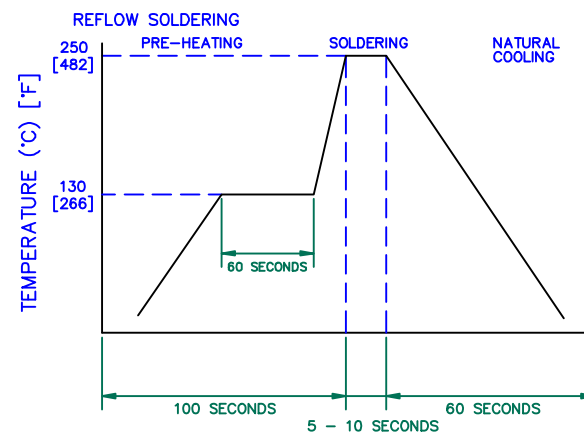

FREQUENCY (MHz)
|Z|, R, AND X vs. FREQUENCY

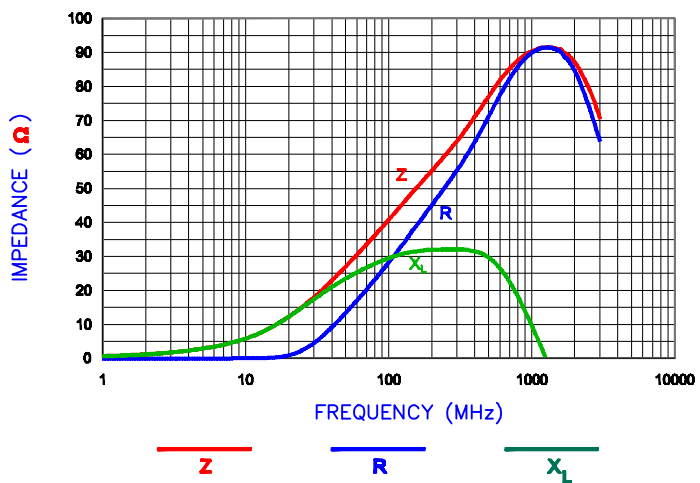

DIMENSIONS ARE IN mm [INCHES].

This print is the property of Laird Tech. and is loaned in confidence subject to return upon request and with the understanding that no copies shall be made without the written consent of Laird Tech. All rights to design or invention are reserved.



| | | | | |
|------------------------|----------------------------|------------|---------------|-----------|
| PROJECT/PART NUMBER: | | REV | PART TYPE: | DRAWN BY: |
| LI0402C470R-10 | | C | CO-FIRE | JRK |
| C | UPDATE COMPANY LOGO | 07/08/08 | JRK | |
| B | CORRECT DC BIAS CURVE DATA | 07/27/07 | JRK | |
| A | ORIGINAL DRAFT | 07/24/07 | JRK | |
| REV | DESCRIPTION | DATE | INT | |
| DATE: 07/24/07 | | SCALE: NTS | SHEET: 2 of 2 | |
| GAD # LI0402D470R-10-C | | TOOL # - | | |